

MODEL 751RB HEAVY DUTY ROLLER BED BELT CONVEYOR

24 HOUR SHIPMENTS INCLUDE ALL 1-FOOT INCREMENTS 5'-0" TO 100'-0"



Conveyor shown with optional supports

Roach 751RB is the choice for heavier unit loads. The heavy duty roller bed construction makes model 751RB ideal for transporting heavy loads with low power requirements.

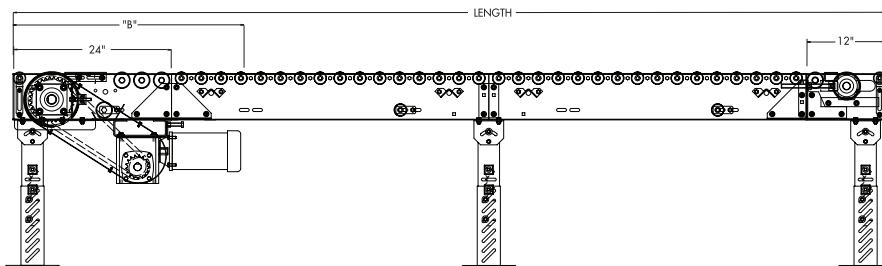
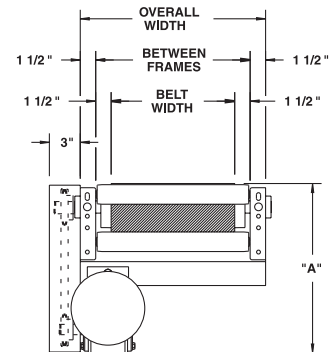

HP@ 60 FPM	"A" MAX 8" DRV.	"B" MAX 8" DRV.
1	17-1/4"	34-15/32"
1-1/2"	18-1/8"	37-3/32"
2	19"	38-3/32"
3	19-1/2"	39-9/32"

SPECIFICATIONS

BELTING: PVC-120 black.

CARRIER ROLLERS: 2-1/2" dia. x 11 ga. steel, model 251S.

DRIVE PULLEY: 8" dia. with 1-7/16" dia. shaft on 15"-39" BF; 12" dia. with 1-15/16" dia. shaft above 39" BF; both machine crowned and fully lagged.

TAIL PULLEY: 4" dia. with 1-3/16" dia. shaft on 15"-39" BF; 6" dia. with 1-7/16" dia. shaft above 39" BF; both machine crowned.

RETURN ROLLERS: 1.9" dia. x 16 ga. steel, model 196S, adjustable.

BELT SPEED: 35 FPM, constant.

END DRIVE: Allows one-direction (unit) operation; add optional center drive for reversible application.

TAKE-UP: Screw type unit at tail pulley provides 12" belt take-up.

BEARINGS: All pulley bearings are precision, heavy duty, lubricated, ball bearing units with cast iron housings.

BED: 7" x 1-1/2" x 10 ga. channel frame. Bed sections attach with couplings and floor supports.

SAFETY POP-OUT ROLLERS: Standard on both ends, 1.9" x 12 ga. steel, model 192S on 15"-39" BF, 1.9" x 9 ga. steel, model 199S on 45"-57" BF.

SQUARING RODS: Adjustable rods on underside of bed allow frame to be squared for improved belt tracking and are standard on all units over 30'.

ROLLER CHAIN: Drive pulley is driven by No. 50 roller chain for 1-1/2 HP or less and No. 60 chain on larger drives. Chain take-up provided on motor base.

MOTOR DRIVE: 1 HP, 230/460/3, 60 cycle, ODP right angle gear motor.

ELECTRICAL CONTROLS: Optional.

⚠ WARNING

Prevent pinch points that exist when belt conveyors are permanently attached to other conveyors or equipment!



SPECIFICATION TABLE

■ 24 hour shipment ■ 3 week shipment

CONVEYOR LENGTH			10'	20'	30'	40'	50'	60'	70'	80'	90'	100'	Deduct
BF	OAW	BELT	UNIT WEIGHTS (lbs.) with 6" Roller Centers (For other centers, deduct weights below)										Per Foot
15"	18"	12"	499	892	1285	1677	2070	2463	2856	3248	3641	4034	39
21"	24"	18"	619	1104	1588	2073	2557	3042	3526	4011	4495	4980	49
27"	30"	24"	739	1315	1892	2468	3044	3620	4197	4773	5349	5925	57
33"	36"	30"	859	1527	2193	2863	3531	4199	4867	5535	6203	6871	67
39"	42"	36"	979	1739	2499	3258	4018	4778	5538	6297	7057	7817	76
45"	48"	42"	1099	1951	2802	3654	4505	5357	6208	7060	7911	8763	85
51"	54"	48"	1219	2162	3106	4049	4992	5935	6879	7822	8765	9708	94
57"	60"	54"	1339	2374	3409	4444	5479	6514	7549	8584	9619	10654	104

Deduct the following weights (lbs.) for other than 3" centers

Roller Centers	15" BF	21" BF	27" BF	33" BF	39" BF	45" BF	51" BF	57" BF
	Per 10'	Per 10'	Per 10'	Per 10'	Per 10'	Per 10'	Per 10'	Per 10'
4-1/2"	-72	-90	-112	-136	-158	-178	-200	-220
6"	-144	-180	-224	-272	-316	-356	-400	-440
9"	-186	-234	-300	-354	-410	-464	-518	-572
12"	-216	-270	-336	-408	-474	-534	-600	-660

OPTIONAL EQUIPMENT

BELTING: Black PVC ruff-top; 3-ply brown neoprene ruff-top; PVC-120 white food grade COS; PVC-150 black COS; 3-ply CN 40 urethane cover. Consult factory for other belting.

CENTER DRIVE: Reversible drive with integral belt take-up of 24". Specify location. Center drive option available on units 6'-0" long and above.

SIDE MOUNTED END DRIVE: Provides minimum conveyor height of 12" TOB (8" dia. drive pulley); 16" TOB (12" dia. drive pulley).

OVERHEAD END DRIVE: Provides minimum conveyor height of 12" TOB (8" dia. drive pulley); 16" TOB (12" dia. drive pulley).

AUXILIARY TAKE-UP: Provides 24" of belt take-up. Specify location. See Power Accessories.

FLOOR SUPPORTS: Supports, knee braces, casters and polytier supports available. See Conveyor Accessories.

GUARD RAILS: HFSG in 2", 4" and 6" heights; 1-1/2" angle (model HGA1-1/2). See Conveyor Accessories.

NOSE-OVER: Provides smooth transition from incline to horizontal position. Consult factory.

SIDE TABLES: Available in 9", 15" and 21" widths. Consult factory.

BELT SPEED: Constant speed 12-120 FPM; DC variable speed; AC inverter variable speed. Other constant or variable speeds available.

NOTE: CAPACITY CHANGES WITH SPEED.

CEILING HANGERS: Heavy duty with hardware to attach rods to conveyor. Consult factory.

MOTORS: Available through 3 HP in TEFC, explosion proof, dirty duty, brake motor, 115/230/1, 575/3, etc.

ELECTRICAL CONTROLS: Magnetic starter (one direction or reversible); One direction manual starter; Momentary start/stop push button station; Forward/reversing /stop push button station. Mounting and pre-wiring for units up to 12' long.

