

190-LRC

The Model 190-LRC is a medium-duty live roller curve that provides a positive drive for negotiating 30°, 45°, 60°, or 90° turns. It may be self-powered or can be slave driven from 190-ACC, LRS or LRSS conveyors.

Live Roller Curve Conveyor

- 12 Bed Widths
- Reversible
- Tapered Tread Rollers
- Adjustable MS-Type Floor Supports Available



Conveyor shown with optional floor supports

| Between Rail Width | Overall Frame Width | "R" | Total Number of Rollers* | | | | WEIGHTS (Lbs.) | | | |
|--------------------|---------------------|---------|--------------------------|---------|---------|---------|----------------|-----|-----|-----|
| | | | 90° | 60° | 45° | 30° | 90° | 60° | 45° | 30° |
| 13" | 16" | 24" | 16T/4S | 10T/12S | 8T/12S | 5T/12S | 336 | 330 | 323 | 317 |
| 15" | 18" | | | | | | 349 | 343 | 336 | 300 |
| 17" | 20" | | | | | | 364 | 357 | 350 | 343 |
| 19" | 22" | | | | | | 378 | 371 | 364 | 357 |
| 21" | 24" | | | | | | 393 | 386 | 378 | 371 |
| 23" | 26" | 32 1/2" | 20T/4S | 14T/12S | 10T/12S | 7T/12S | 408 | 401 | 393 | 386 |
| 25" | 28" | | | | | | 425 | 417 | 409 | 401 |
| 27" | 30" | | | | | | 442 | 434 | 425 | 417 |
| 31" | 34" | | | | | | 562 | 551 | 540 | 529 |
| 33" | 36" | | | | | | 585 | 573 | 562 | 550 |
| 37" | 40" | 48" | 30T/4S | 22T/12S | 14T/12S | 10T/12S | 625 | 613 | 601 | 589 |
| 39" | 42" | | | | | | 651 | 638 | 625 | 612 |

*T = TAPERED S = STRAIGHT
All weights in catalog are conveyor weights only. Accessories, crating, etc., are not included.

STANDARD SPECIFICATIONS

BED—Roller bed with 2 1/2 in. dia. tapered to 1 3/4 in. dia. x 14 ga. galvanized and 1.9 in. dia. roller x 16 ga. galvanized tube. Mounted in 6 1/2 in. x 12 ga. powder painted formed steel channel frame.

END DRIVE—Mounted underneath bed section on outside radius.

DRIVING BELT—Endless B-section V-Belt, industrial grade.

PRESSURE SHEAVES—2 1/2 in. dia. with 3/8 in. bore.

IDLER SHEAVE—4 in. dia. x 5/8 in. bore V type and/or 5 1/2 in. dia. x 5/8 in. bore flat type.

TAKE-UP—Take-ups provided to maintain proper V-belt tension. Includes 4 3/8 in. dia. x 5/8 in. bore V type take-up sheave.

BEARINGS—Tread rollers have pre-lubricated ball bearings. Flange and pillow block bearings are sealed, pre-lubricated with eccentric lock collar.

BUTT COUPLINGS—Standard for connecting 190-ACC, 190-LRS, 190-LRSS, 190-ACZ, or 190-LR conveyors.

SPEED REDUCTION—Sealed worm gear speed reducer driven by V-belt. No. 50 roller chain to drive sheave.

MOTOR—1/2 HP—208/230/460/575V—3 PH. 60 Hz. Totally Enclosed.

CONVEYING SPEED—Constant 65 FPM.

CAPACITY—500 lbs. total distributed live load.

FLOOR SUPPORTS—Now supplied as optional equipment.

Horsepower required to slave-drive LRC's & LRCT's from ACC's affect the lengths of ACC's due to the capacities of the driving V-belt. The four (4) arrangements shown, illustrate basic slave limitations. Other arrangements are possible.

- NOTES**
- CURVES MAY BE 30°, 45°, 60°, & 90°
 - CURVES ARE NOT ACCUMULATING
 - SNUB ROLLER ADJUSTMENT IS ON DRIVE BELT SIDE OF CONVEYOR

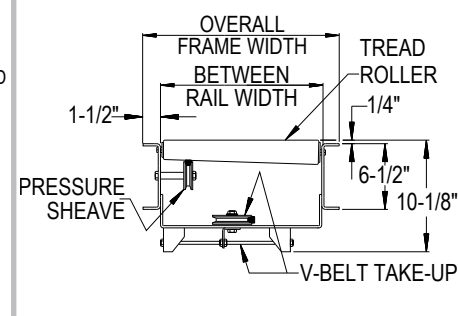
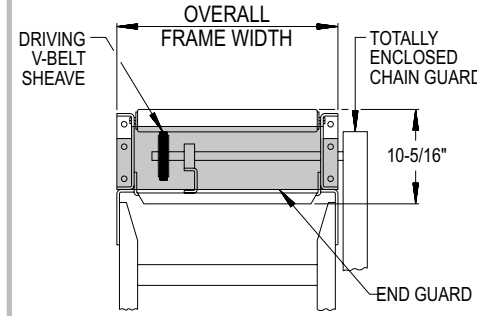
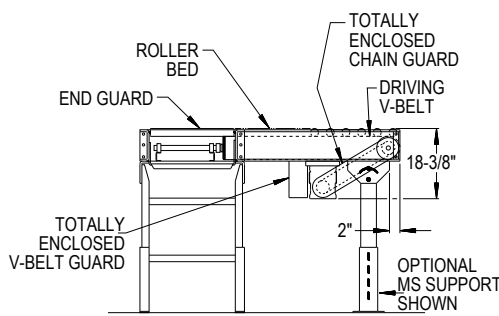

SECTION "X-X"

SECTION "Y-Y"

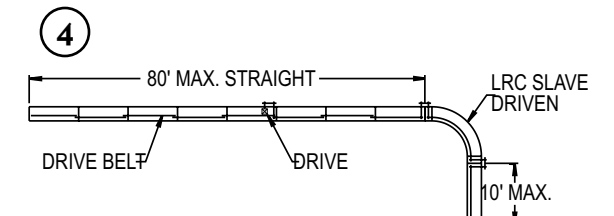
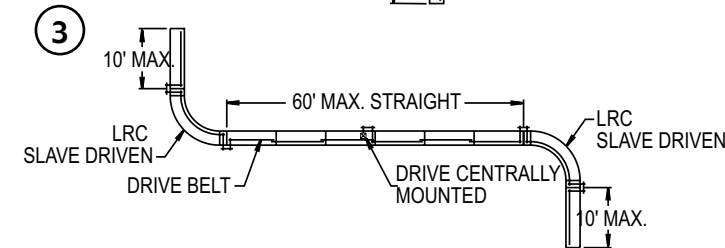
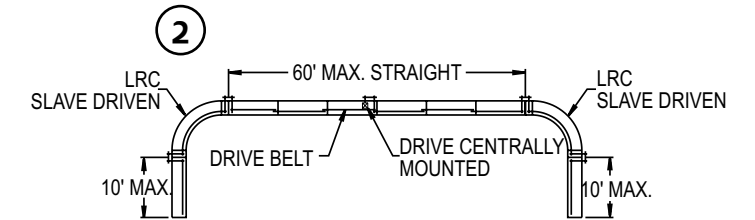
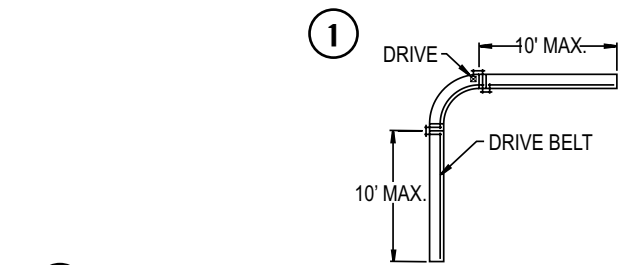
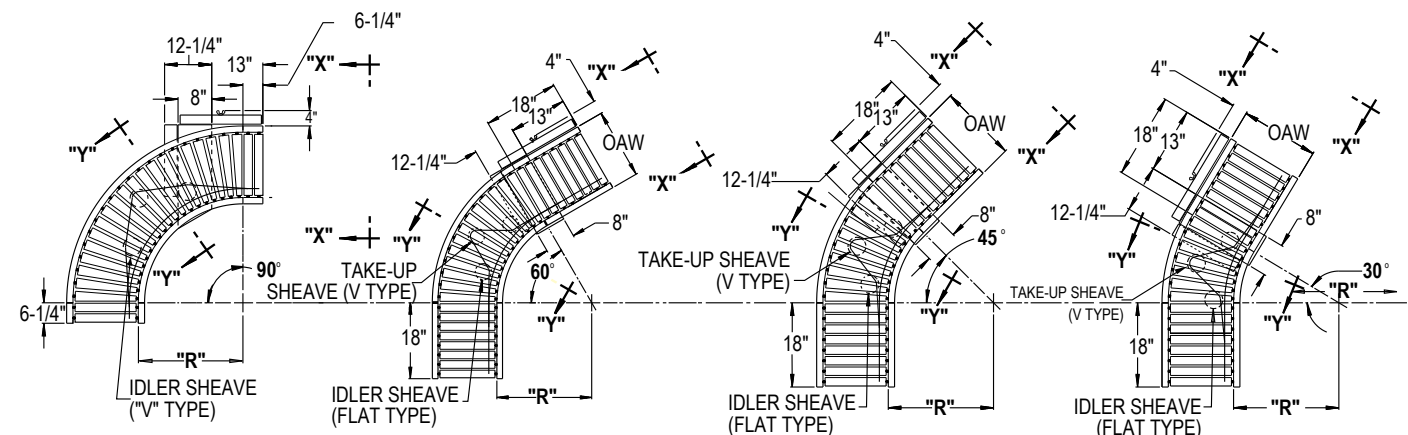

OPTIONAL EQUIPMENT

FLOOR SUPPORTS—MS Type floor supports are available with a wide range of adjustment. Specify top of belt or roller elevation. One support required at every bed joint and ends of conveyor. Holes in feet for lagging to floor. Knee braces recommended above MS-6 support.

CONVEYING SPEED—Other constant and variable speeds from 25 to 120 FPM. **Note:** Capacity affected with speed change.

END DRIVE—Mounted on inside radius. Minimum elevation 18 7/8".

SIDE MOUNTED DRIVE—Motor reducer unit mounted to side of conveyor. Specify inside or outside. Minimum elevation 11 1/2 in.

O-RING DRIVE CHAIN—With sealed in lubricant (Recommended for applications that do not permit regular lubrication).

GUARD RAILS—Adjustable Universal Channel Guard Rail, fixed channel or type A & B angle. (See Accessory section.) **Note:** If product comes in contact with guard rails, product flow will be affected.

POLY-TIER SUPPORTS—36 in. to 120 in. support heights in 6 in. increments. Knee braces supplied.

CEILING HANGERS—3/8 in. dia. x 8 ft. long unplated rods fully threaded. Other lengths and galvanized rods available.

SLAVE DRIVEN—Standard drive may be omitted and curve slave driven from 190-ACC, 190-ACZ, or 190-LR conveyors. (Specify by sketch, location of slave connection). Minimum elevation 11 in.

MOTORS—Energy efficient, single phase, brakemotor, other characteristics. 1 HP maximum.

ELECTRICAL CONTROLS—Non-reversing or reversible magnetic starters and push-button stations. AC variable frequency drive.

