

25-CRR

Chain Driven Live Roller Conveyor (Roll-to-Roll Type)

The heavy design of the 25-CRR allows it to be used for conveying higher load capacities such as loaded pallets and drums. Chain driven rollers make it ideal for conveying oily parts in bottling and steel industries.

- 15 Bed Widths
- Center Drive
- Reversible
- Chain Driven Rollers
- Adjustable HSN-Type Floor Supports Available



Conveyor shown with optional floor supports

4 in., 5 in., 6 in., and 7 1/2 in. Roller Centers

Conveying Surface		15 3/4"	17 3/4"	19 3/4"	21 3/4"	23 3/4"	27 3/4"	29 3/4"	33 3/4"	35 3/4"	39 3/4"	43 3/4"	47 3/4"	51 3/4"	57 3/4"	63 3/4"
Between Rail Width		19"	21"	23"	25"	27"	31"	33"	37"	39"	43"	47"	51"	55"	61"	67"
Overall Frame Width		22 1/4"	24 1/4"	26 1/4"	28 1/4"	30 1/4"	34 1/4"	36 1/4"	40 1/4"	42 1/4"	46 1/4"	50 1/4"	54 1/4"	58 1/4"	64 1/4"	70 1/4"
*4" Centers 10' Length-O.A.	No. 40	722	750	778	806	834	890	918	974	1002	1058	1114	1170	1226	1310	1394
Per Foot	Chain	61	64	67	70	73	79	82	88	91	97	103	109	113	124	133
5" Centers 10' Length-O.A.	No. 50	638	666	694	721	749	804	823	887	915	970	1026	1081	1136	1219	1302
Per Foot	Chain	54	57	60	63	66	72	75	81	84	90	96	102	108	117	126
6" Centers 10' Length-O.A.	No. 60	582	610	638	666	694	750	778	834	862	918	974	1030	1086	1170	1254
Per Foot	Chain	49	52	55	58	61	67	70	76	79	85	91	97	103	112	121
7 1/2" Centers 10' Length-O.A.	No. 60	526	554	582	610	638	694	722	778	806	862	918	974	1030	1114	1198
Per Foot	Chain	46	49	52	55	58	64	67	73	76	82	88	94	100	109	118

#40 chain reduces total conveyor capacity. Consult factory.

3 3/4 in. Roller Centers

Conveying Surface		15 3/4"	17 3/4"	19 3/4"	21 3/4"	23 3/4"	27 3/4"	29 3/4"	33 3/4"	35 3/4"	39 3/4"	43 3/4"	47 3/4"	51 3/4"	57 3/4"	63 3/4"
Between Rail Width		22"	24"	26"	28"	30"	34"	36"	40"	42"	46"	50"	54"	58"	64"	70"
Overall Frame Width		25 1/4"	27 1/4"	29 1/4"	31 1/4"	33 1/4"	37 1/4"	39 1/4"	43 1/4"	45 1/4"	49 1/4"	53 1/4"	57 1/4"	61 1/4"	67 1/4"	73 1/4"
3 3/4" Centers 10' Length-O.A.	No. 60	750	778	806	833	861	916	944	999	1027	1083	1137	1193	1249	1332	1415
Per Foot	Chain	63	68	71	74	77	83	86	92	95	101	107	113	119	128	137

3 in. Roller Centers with Chain Guard on both sides

Conveying Surface		15 3/4"	17 3/4"	19 3/4"	21 3/4"	23 3/4"	27 3/4"	29 3/4"	33 3/4"	35 3/4"	39 3/4"	43 3/4"	47 3/4"	51 3/4"	57 3/4"	63 3/4"
Between Rail Width		22 1/4"	24 1/4"	26 1/4"	28 1/4"	30 1/4"	34 1/4"	36 1/4"	40 1/4"	42 1/4"	46 1/4"	50 1/4"	54 1/4"	58 1/4"	64 1/4"	70 1/4"
Overall Frame Width		25 1/2"	27 1/2"	29 1/2"	31 1/2"	33 1/2"	37 1/2"	39 1/2"	43 1/2"	45 1/2"	49 1/2"	53 1/2"	57 1/2"	61 1/2"	67 1/2"	73 1/2"
3" Centers 10' Length-O.A.	No. 60	862	890	918	946	974	1030	1058	1114	1142	1198	1254	1310	1366	1450	1534
Per Foot	Chain	72	75	78	81	84	90	93	99	102	108	114	120	126	135	144

3 in. Roller Centers with Chain Guard on one side

Conveying Surface		17 3/4"	19 3/4"	21 3/4"	23 3/4"	25 3/4"	29 3/4"	31 3/4"	35 3/4"	37 3/4"	41 3/4"	45 3/4"	53 3/4"	59 3/4"	63 3/4"	65 3/4"
Between Rail Width		22"	24"	26"	28"	30"	34"	36"	40"	42"	46"	50"	58"	64"	68"	70"
Overall Frame Width		25 1/4"	27 1/4"	29 1/4"	31 1/4"	33 1/4"	37 1/4"	39 1/4"	43 1/4"	45 1/4"	49 1/4"	53 1/4"	61 1/4"	69 1/4"	71 1/4"	73 1/4"
3" Centers 10' Length-O.A.	No. 40	750	778	806	833	861	916	944	999	1027	1083	1137	1193	1249	1332	1415
Per Foot	Chain	63	68	71	74	77	83	86	92	95	101	107	113	119	128	137

All weights in catalog are conveyor weights only. Accessories, crating, etc. are not included

Note: Add 1 3/8" to OAL for Chain Guard End Caps on 4" centers only.

Note: Add 3" to OAL for Chain Guard End Caps on 3" roller centers only.



• STANDARD SPECIFICATIONS

BED—Roller bed with 2 1/2 in. dia. x 11 ga. unplated tread rollers spaced every 4 in. with No. 40 roller chain; 5 in. with No. 50 roller chain. No. 60 roller chain used on 3 in., 3 3/4 in., 6 in., and 7 1/2 in. roller centers only. Tread rollers mounted in 4 in. x 4 ga. powder painted formed steel channel on side opposite chain guard and 6 in. x 4 ga. powder painted formed steel channel on chain guard side. **NOTE:** 3 in. roller center tread rollers mounted in 4 in. channel each side.

CENTER DRIVE—Can be placed in any section of conveyor length, specify. Chain guard located on left hand side.

DRIVE CHAIN—No. 40, 50 or 60 roller chain.

CHAIN GUARD—Formed steel, upper and lower chain guard mounted to top and bottom of channel frame to totally enclose drive chains.

BEARINGS—Sealed, pre-lubricated ball bearings.

SPEED REDUCTION—Sealed worm gear C-Face speed reducer.

MOTOR—1 HP—208/230/460/575V—3 Ph. 60 Hz. Premium Energy Efficient C-Face.

CONVEYING SPEED—Constant 30 FPM.

CAPACITY—Maximum load per linear foot of conveyor 300 lbs. with supports on 10 ft. centers, 1000 lbs. with supports on 5 ft. centers. Contact factory for capacity of No. 40 chain, 4 in. roller centers. **NOT TO EXCEED CAPACITY IN CHART.**

FLOOR SUPPORTS—Now supplied as optional equipment.

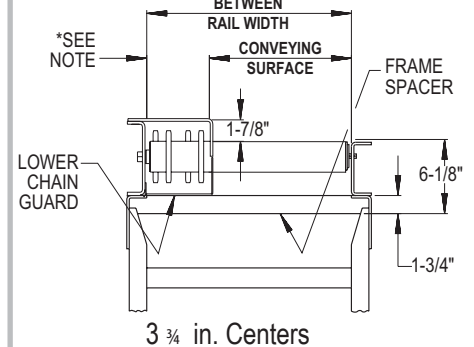
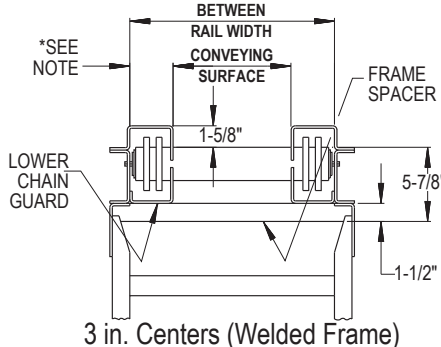
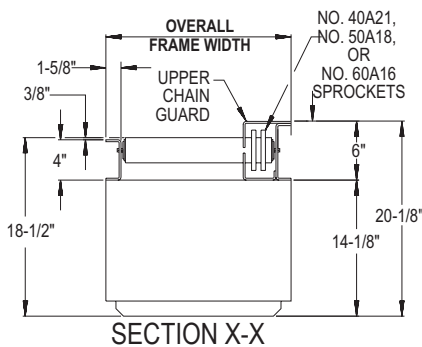
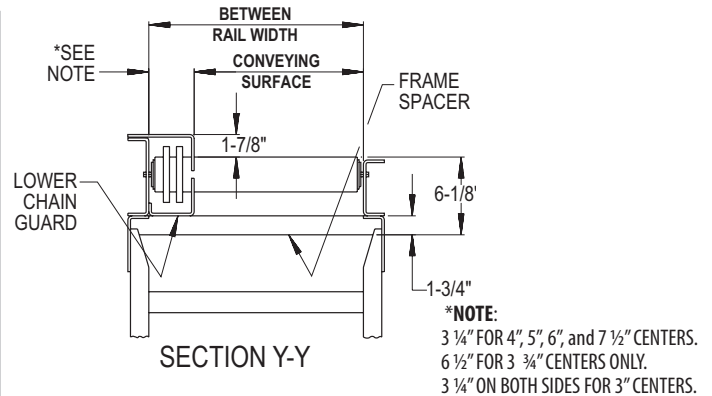
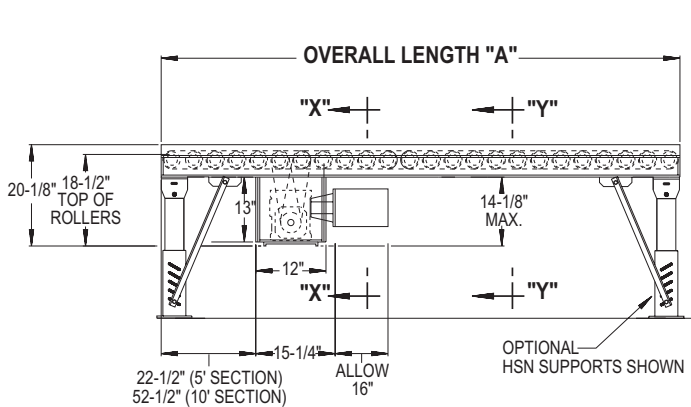

LOAD CAPACITY CHART @ 30 FPM		
TOTAL LOAD (Lbs.)		
HP	UP TO 50'	UP TO 100'
1	9000	6000
2	22000	18000

NOTE: Capacities are calculated on 5" Roller Centers with #50 Chain.

• OPTIONAL EQUIPMENT

FLOOR SUPPORTS—HSN Type floor supports are available with a wide range of adjustment. Specify top or roller elevation. One support required at every bed joint and ends of conveyor. Holes in feet for lagging to floor. Knee braces recommended above HSN-3 support.

CONVEYING SPEED—Other constant and variable speeds. V-belt supplied on speeds under 12 FPM (1 HP). **NOTE:** Capacity affected with speed change.

TOP SIDE MOUNTED DRIVE—Motor reducer unit mounted to side of conveyor with drive chain through top of chain guard. Specify clearances. Minimum elevation top of rollers 6 1/2 in.

V-BELT DRIVE—V-belt supplied between motor and reducer.

SHAFT MOUNTED DRIVE—Mounted to side of conveyor complete with torque arm. Minimum elevation to top of rollers is 6 1/2 in.

O-RING DRIVE CHAIN—With sealed in lubricant (Recommended for applications that do not permit regular lubrication).

FRAMES—4 in. X 5.4 lb. structural channel (welded).

GUARD RAILS—Fixed angle (2 in. high x 1/4 in. steel) guard bolts to top flange of channel opposite chain guard.

CHANNEL END STOP—6" x 8.2 lb. structural channel end stop.

ROLLERS SET LOW—Tread rollers mounted in 6 in. x 4 ga. formed steel channel frame to form 1 3/8 in. high guard rails. Also available in 5 in. x 6.7 lbs. structural channel frame (welded). Specify.

CHAIN CROSSOVER—Separate 3-roller section moves driving chain from one side of conveyor to other. Offset-style adds 9 in. with 3" roller centers, 12 in. to OAL of conveyor with 4" roller centers, 15 in. with 5" roller centers, & 18 in. with 6" roller centers.

TRANSFERS—Chain transfers available. See Accessory section.

MOTORS—Single phase, brakemotor, other characteristics. 2 HP maximum.

ELECTRICAL CONTROLS—Non-reversing magnetic starter – push-button stations. AC variable frequency drive.